

Orbi-flex^X Gearboxes for Roller Presses

Engineered Drive Solutions for Grinding and Milling Applications

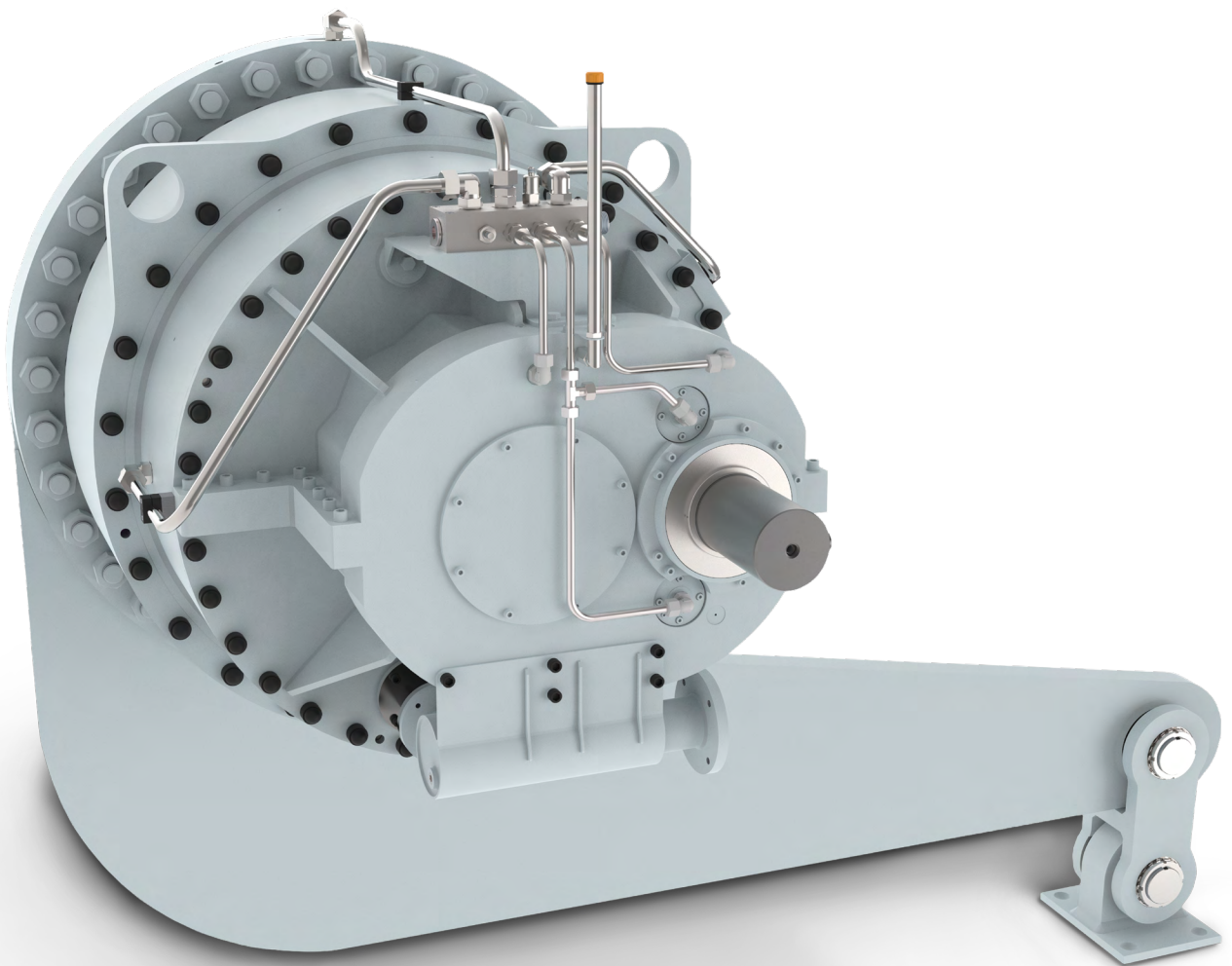

WIKOV

The Essence of Engineering

Orbi-flex Gearboxes for HPGR

Ultimate cost effective solution of a planetary gearbox driving high-pressure grinding rolls is field proven technology. It is designed to maximally reduce operation costs and maintenance requirements while ensuring extended lifetime of the gearbox and minimize wear of gearbox internals.

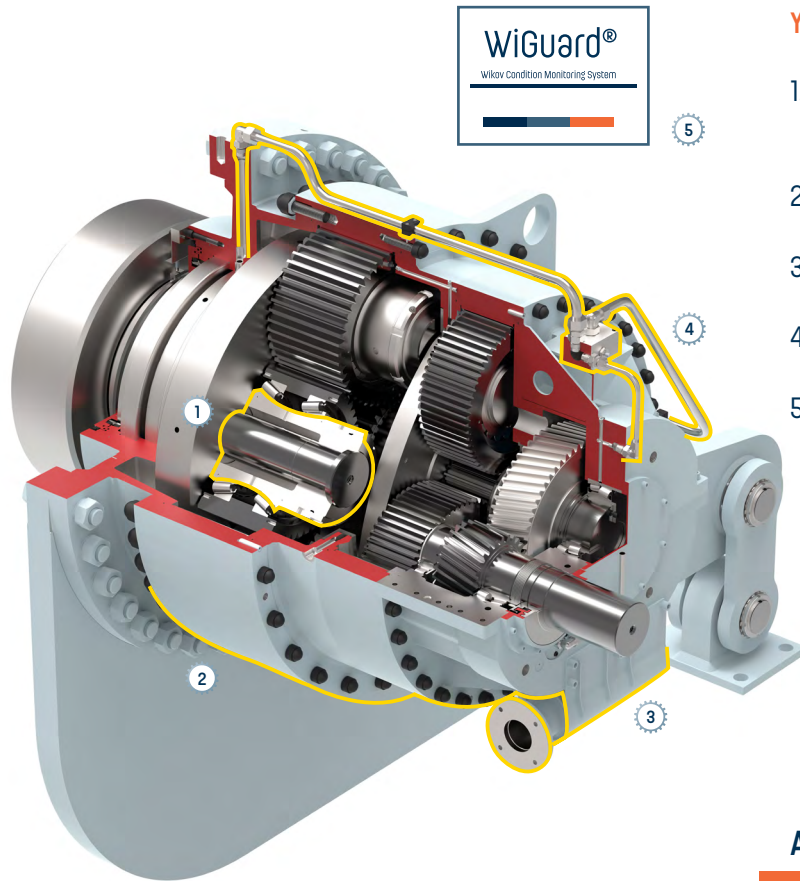

Your benefits with Wikov Roller Press Gearbox

1. **Flexible pin** for high torque stage to protect gears and bearings against damage when shock loads occur; available with patented **overload stop** feature
2. **Smart gearbox** oil drain to prevent accumulation of impurities inside the gearbox housing
3. **Dry sump oil system** for extended lifetime of the oil and the gearbox
4. Advanced **easy-to-maintain lubrication system** with oil feed to all key components
5. **WiGuard** - remote condition monitoring of the gearbox operation

Advantages of Wikov Roller Press Gearboxes

Long oil change interval saving costs for consumables

Dry gearbox with external lubrication system

Gearbox components kept free of impurities in the oil

Higher resistance against shock load conditions

Optimized meshing accuracy of gears

Extended gearbox lifetime

Small footprint

Environmentally friendly

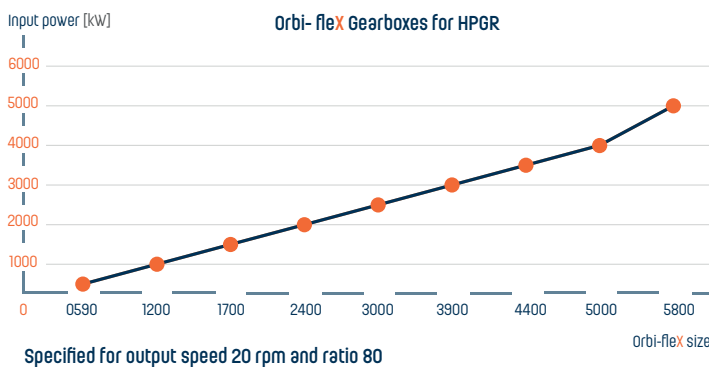

Parameter	Value
Power (kW)	500-5000
Torque (kNm)	597-5968
Ratio	40-90

Other specifications available upon request.

Contacts

Wikov Gear s. r. o.

Tylova 1/57, 316 00 Pilsen, Czech Republic
T +420 377 177 110, F +420 377 177 119, E gear@wikov.com, www.wikov.com