

# Gears for Heavy-Duty Combustion Engines

Engineered Solutions for Diesel and Gas Engines

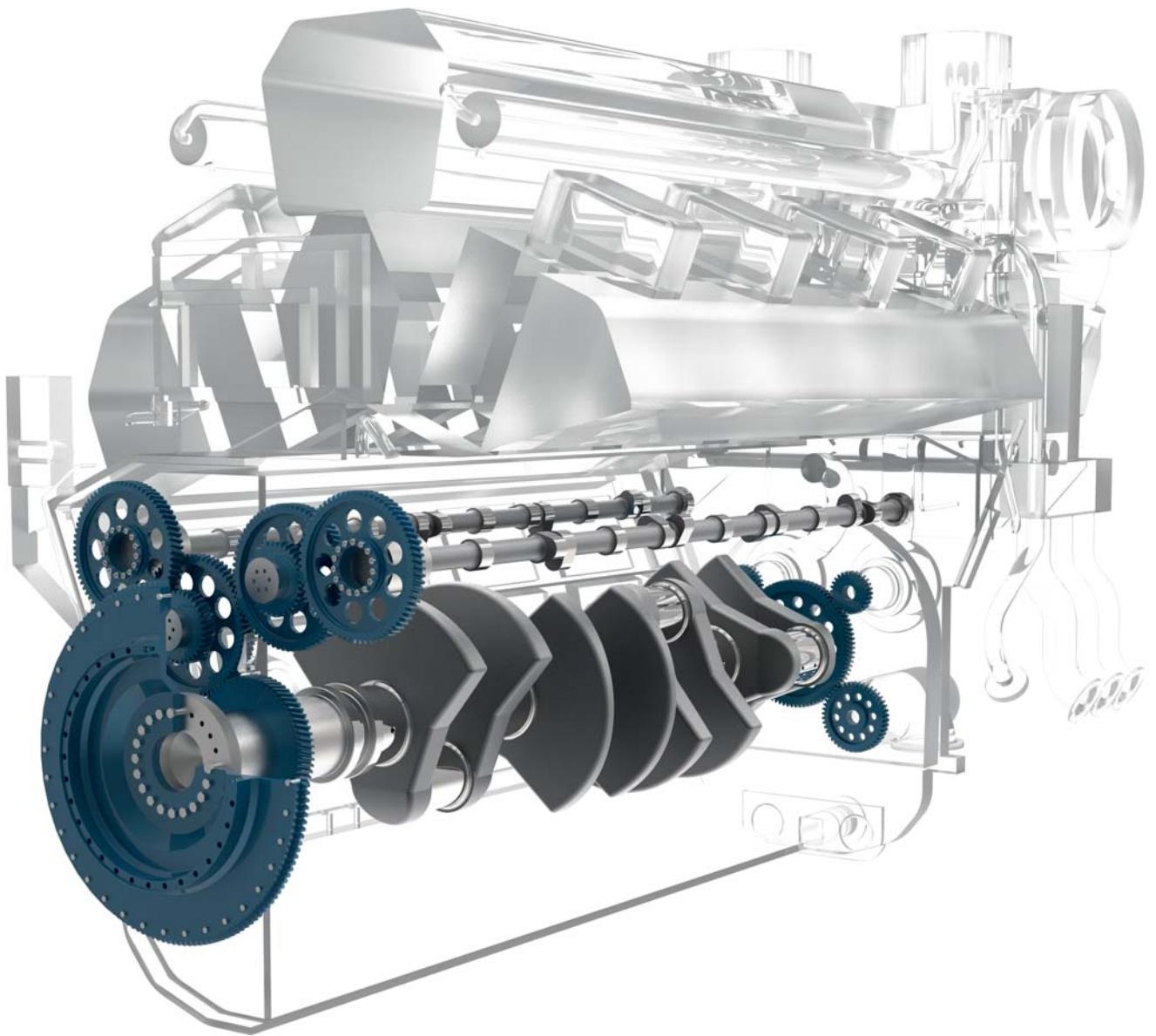

**WIKOV**

**The Essence of Engineering**

# Engine Gears

Precise gear parts manufactured with emphasis on cost efficiency by a gearbox manufacturer with 100 year tradition and experience. We use state-of-the-art machine tools and own heat treatment facility. All operations are controlled and assessed using first class measuring devices. Gear geometry is verified on the Klingelberg P300 machine.



## Wikov Gas and Diesel Engine Gears

1. Timing gears (camshaft drive)
2. Auxiliary drive gears:
  - oil pump
  - water pump
  - fuel pump
  - alternator
3. Flywheel
4. Split gears

## Advantages of Wikov Gears

Material from renowned European suppliers

Advanced production and machine tools

In-house heat treatment facility

Large scale experience in gear manufacturing

	SHAPING / HOBBIING / GRINDING
Module	65 (35 ground)
Outside diameter	3.500 mm (2.800 mm ground)
Accuracy	DIN3961 IT4 (ground)
Max. weight	30.000 kg (8.000 kg ground)
Heat treatment	case hardening / nitriding

### Technical Parameters

#### Contacts

#### Wikov Gear s. r. o.

Tylova 1/57, 316 00 Pilsen, Czech Republic

T +420 377 177 110, F +420 377 177 119, E gear@wikov.com, www.wikov.com